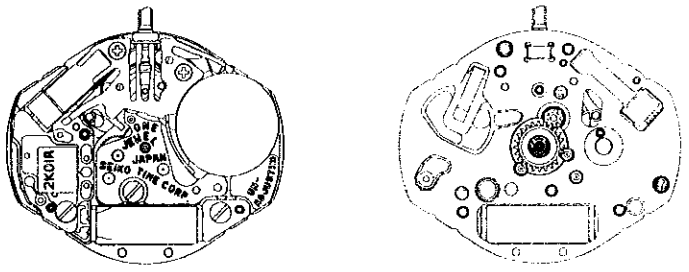

PARTS CATALOGUE/ TECHNICAL GUIDE

Cal. 2K01A

[SPECIFICATIONS]

Item		Cal. No.	2K01A
Movement			 <p style="text-align: right;">(x 2.0)</p>
Movement size	Outside diameter		18.4 mm between 6 o'clock and 12 o'clock sides 15.3 mm between 3 o'clock and 9 o'clock sides
	Casing diameter		φ18.1 mm 17.8 mm between 6 o'clock and 12 o'clock sides
	Height		1.9 mm
Time indication			3 hands
Driving system			Step motor (Load compensated driving pulse type)
Additional mechanism			<ul style="list-style-type: none"> • Electronic circuit reset switch • Train wheel setting device
Loss/gain			Monthly rate at normal temperature range: less than 15 seconds
Regulation system			Nil
Measuring gate by quartz tester			Use 10-second gate
Battery			SEIKO SR616SW, Maxell SR616SW, Sony SR616SW, Matsushita SR616SW Battery life is approximately 2 years. Voltage: 1.55V
Jewels			1 jewel

PARTS CATALOGUE

Cal. 2K01A

Disassembling procedures Figs.: ① → ⑳

Reassembling procedures Figs.: ㉔ → ①

Lubricating: Types of oil

● Moebius A

○ SEIKO Watch Oil S-6

Oil quantity

∞ Normal quantity

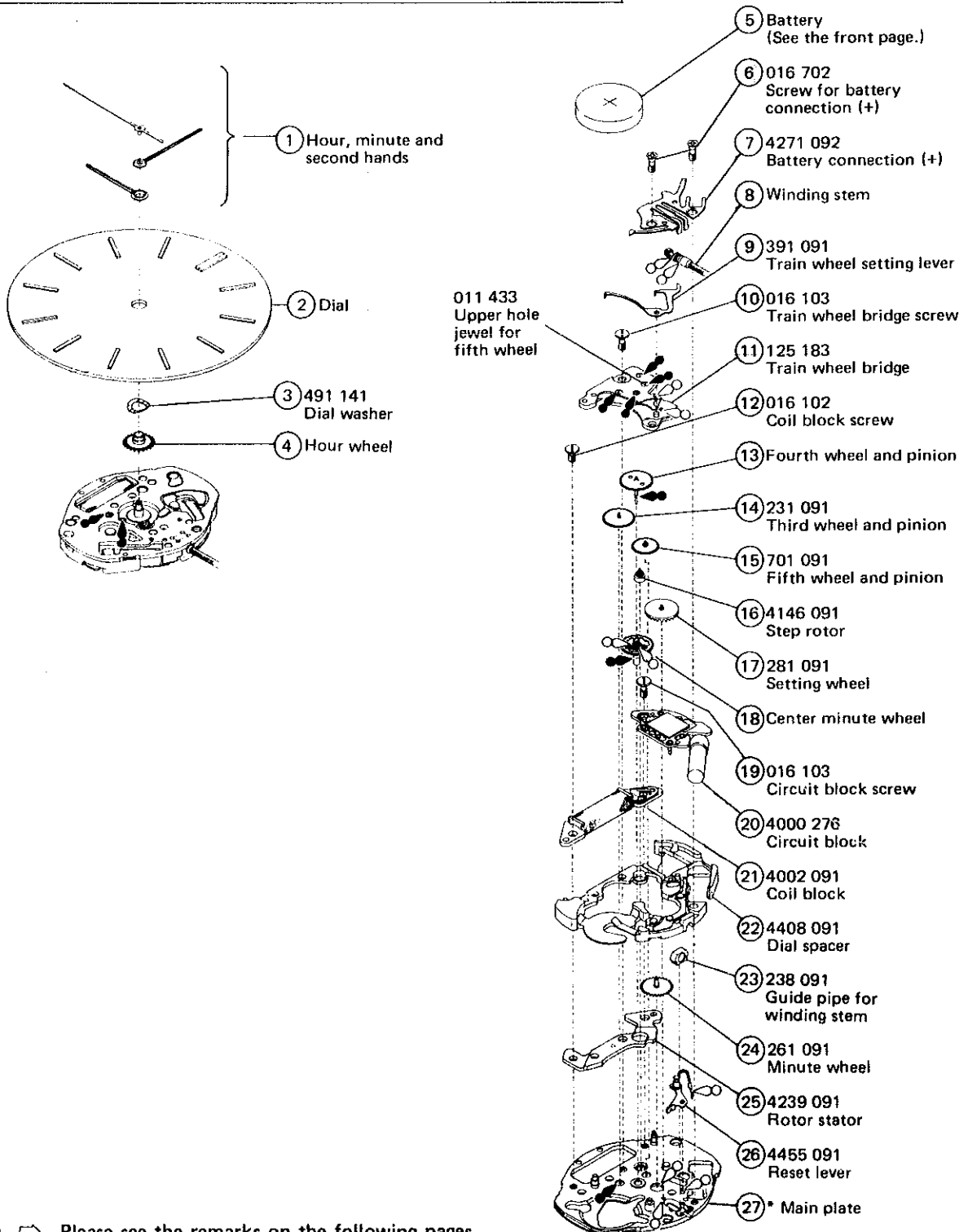



○ ⇨ Please see the remarks on the following pages.

* Unavailable for supply

Remarks:

- ④ Hour wheel
- ⑬ Fourth wheel and pinion
- ⑱ Center minute wheel

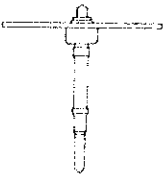
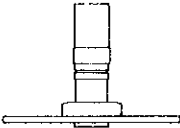
Combination:

Parts name Type*	Fourth wheel and pinion	Center minute wheel	Hour wheel
M	 241 291	 270 468	 271 468

* Abbreviation M Standard type
(Movement type)

- ⑧ Winding stem 351 291

The type of winding stem is determined based on the design of case.
Check the case number and refer to "SEIKO Casing Parts Catalogue" to choose a corresponding winding stem.

LIST OF SCREWS USED

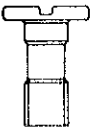
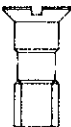
Shape	Part No.	Name
	016 102	⑫ Coil block screw (1 pc.)
	016 103	⑩ Train wheel bridge screw (1 pc.) ⑰ Circuit block screw (1 pc.)
	016 702	⑥ Screw for battery connection (+) (2 pcs.)

- The explanation here is only for the particular points of Cal. 2K01A.
- For the repairing, checking and measuring procedures, refer to the "TECHNICAL GUIDE, GENERAL INSTRUCTIONS".

I. STRUCTURE OF THE CIRCUIT BLOCK

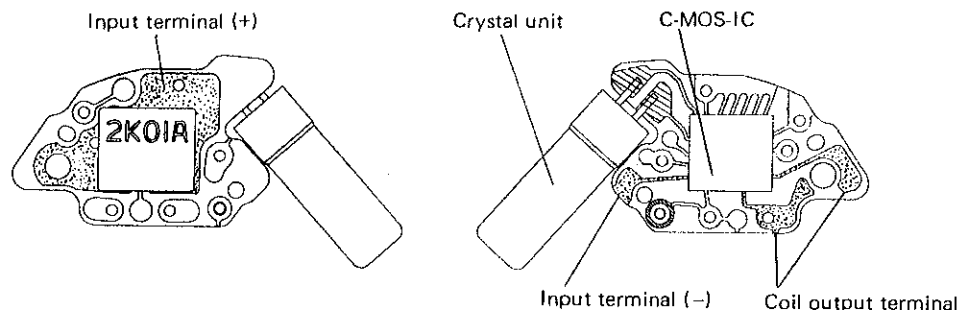

II. REMARKS ON DISASSEMBLING AND REASSEMBLING

Use the universal movement holder for disassembling and reassembling.

⑧ Winding stem

• How to remove

Insert a screwdriver with a little wider tip, twist it alternately right and left as shown by the arrows in the illustration, and remove the winding stem.

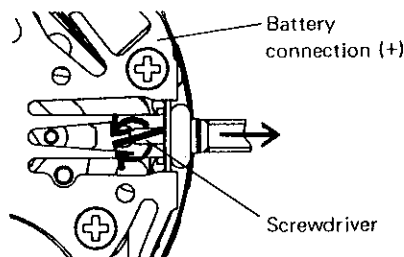

⑨ Train wheel setting lever

• Setting position

Set (A) portion first, and then insert (B) portion into the long slot (B) in the train wheel bridge.

*When setting (A) portion, check it does not touch the fourth wheel and pinion.

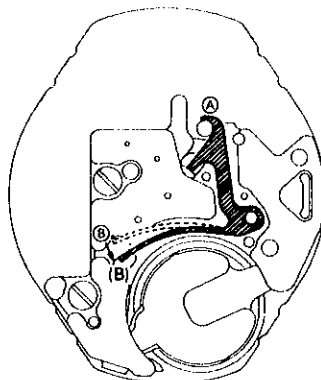

⑪ Train wheel bridge

● **Setting position**

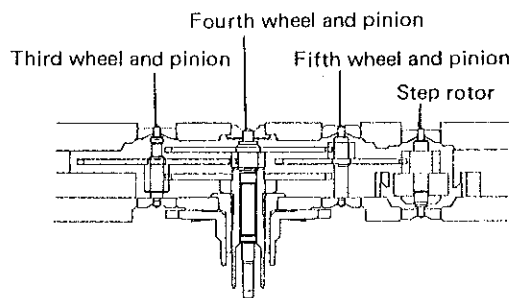
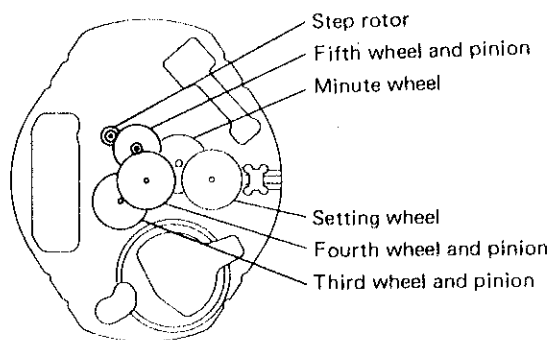

Note: Set the step rotor with its pinion facing toward the main plate side.

III. VALUE CHECKING

● **Coil block resistance**

2.8K Ω ~ 3.2K Ω

● **Current consumption**

For the whole of the movement: less than 1.0 μ A

For the circuit block alone : less than 0.4 μ A

Remarks:

- When the current consumption exceeds the standard value for the whole of the movement but is less than the standard value for the circuit block alone, overhaul and clean the movement parts and then measure current consumption for the whole of the movement again. The driving pulse generated to compensate a heavy load that may apply on the gear train, etc. is considered to cause excessive current consumption for the whole of the movement.